

# CAT SERIES

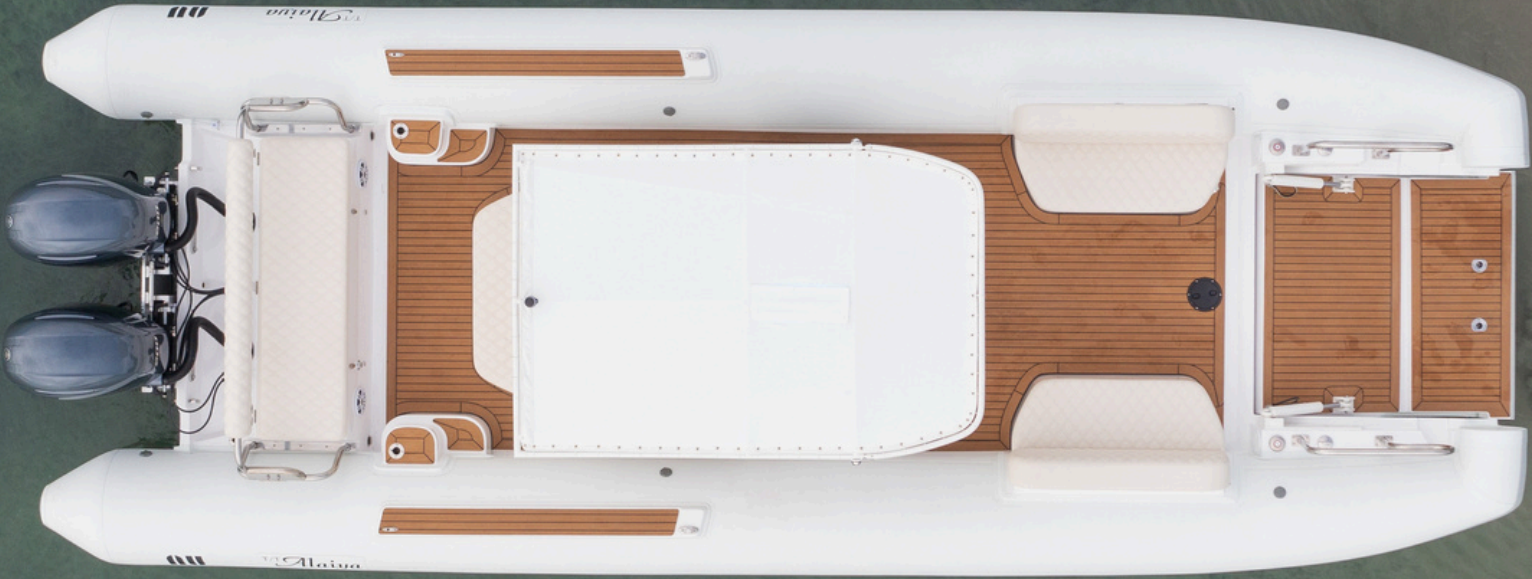

*It is not just about building and designing  
boats, it is what we love to do*

Our passion for detail and sophisticated Italian design has been our secret since the 1960s.

To meet the needs of our clients, in the 1990s our inhouse production was moved from Italy to Florida, one of the most developed marine areas in the world.

Today, Novurania continues to lead the market. Our heritage and innovation guarantee the production of exceptionally beautiful as well as high-quality boats and luxury yacht tenders.



## *A know-how passed on for more than half a century*

Since the beginning, we controlled the main phases of the value chain to guarantee excellence and high quality.

We manufacture our own inflatable tube fabric, coated with neoprene CR on the inside and with Hypalon CSM on the outside, ensuring our vessels durability in strength as well as time.

We are revolutionizing the industry by producing the highest performance line of inflatable boats. We place equal care on the exterior appearance and on the internal technical engineering.























# CAT SERIES

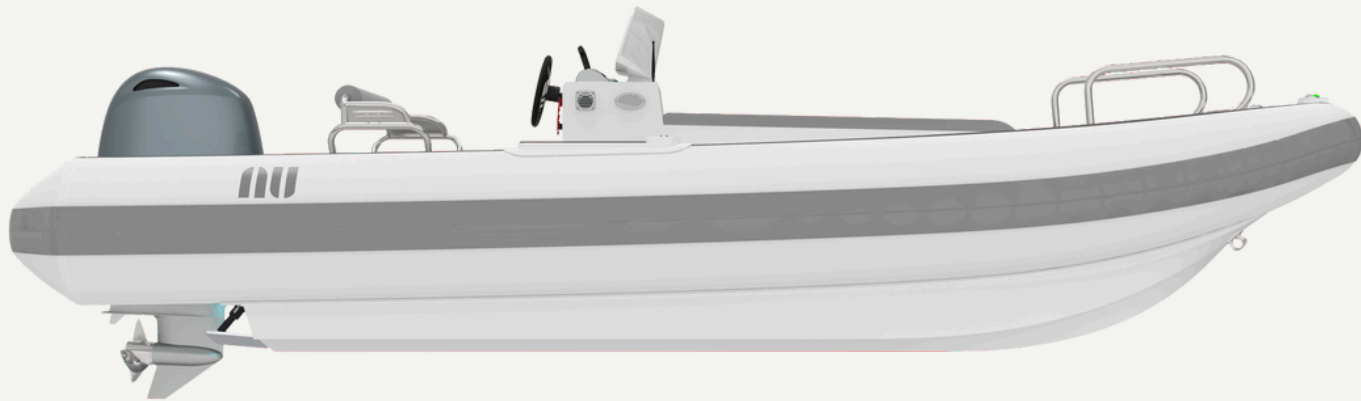

450

20

24  
OB-10

28

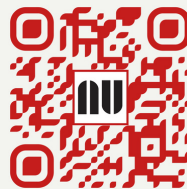



# CAT 450



The CAT 450 is a true standout, boasting a double-hull structure and generous seating that guarantee unmatched comfort for smooth rides.

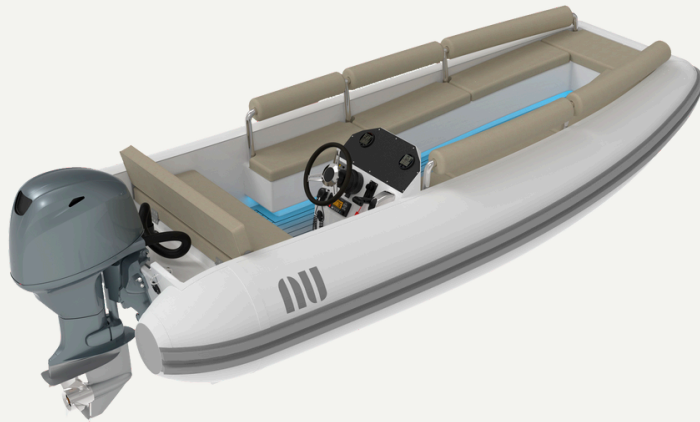

<b>LOA</b> 14'10"/4.52m	<b>Beam</b> 6'8"/2.1m	<b>Seating</b> 7
<b>Max speed</b> 36 mph	<b>Fuel capacity</b> 15 gal./56 l	<b>Water capacity</b> -
<b>Max HP</b> 70 HP OB	<b>CE Category</b> C	<b>Dry weight</b> 1300 lbs./590 kg (incl. engine)









# CAT 20



With its forward hydraulic door, the Catamaran 20 is the perfect beach lander for your superyacht.

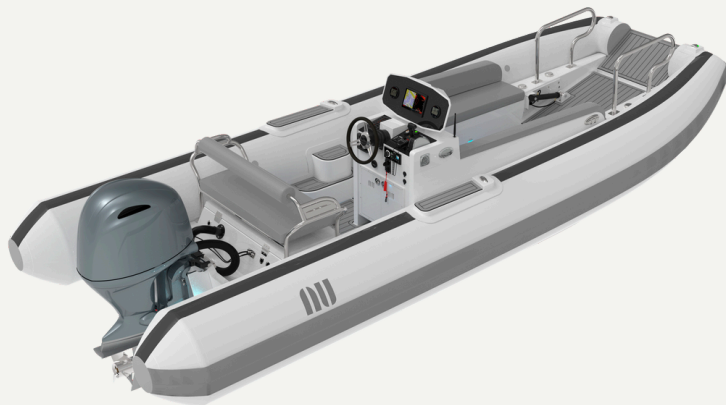

<b>LOA</b> 20'/6.1 m	<b>Beam</b> 7'9"/2.4 m	<b>Seating</b> 8
<b>Max speed</b> 38 mph	<b>Fuel capacity</b> 30 gal./113 l	<b>Water capacity</b> 10 gal./38 l
<b>Max HP</b> 150 HP OB	<b>CE Category</b> C	<b>Dry weight</b> 2650 lbs/1200 kg (incl. engine)







# CAT 24



With its twin hull design the CAT 24 guarantees great space for transporting people, equipment and cargo on the water, beach, and dock.

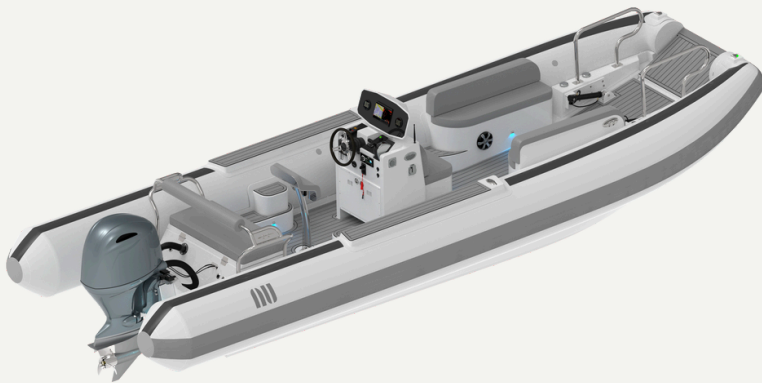

<b>LOA</b> 24'/7.3 m	<b>Beam</b> 8'6"/2.6 m	<b>Seating</b> 10
<b>Max speed</b> 49 mph (OB) 41 mph (IO)	<b>Fuel capacity</b> 52 gal./197 l	<b>Water capacity</b> 20 gal./76 l
<b>Max HP</b> 250 HP OB-IO*	<b>CE Category</b> C	<b>Dry weight</b> 3520 lbs/1600 kg OB 4300 lbs/1950 kg IO* (incl. engine)

\*Diesel Sterndrive







# CAT 28



The Catamaran 28 is the biggest model of the Series. The large forward deck area can carry both people and equipment.

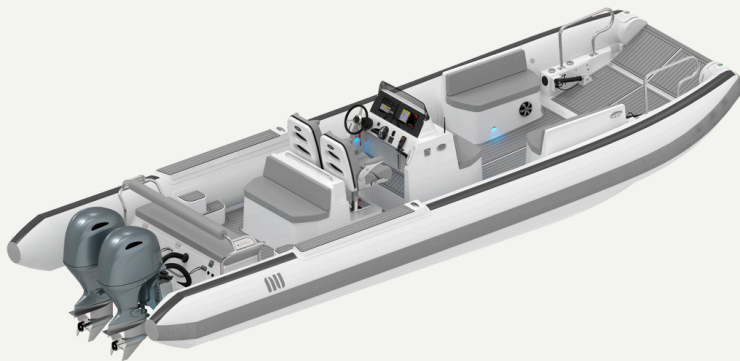

<b>LOA</b> 28'7"/8.7 m	<b>Beam</b> 10'8"/3.3 m	<b>Seating</b> 14
<b>Max speed</b> 47 mph	<b>Fuel capacity</b> 80 gal./303 l	<b>Water capacity</b> 20 gal./76 l
<b>Max HP</b> Twin 200 HP OB	<b>CE Category</b> C	<b>Dry weight</b> 5300 lbs/2404 kg (incl. engine)











**450**

**LOA**  
14'10"/4.52m

**Beam**  
6'8"/2.1m

**Seating**  
7



**20**

**LOA**  
20'/6.1 m

**Beam**  
7'9"/2.4 m

**Seating**  
8



**24<sub>OB-10</sub>**

**LOA**  
24'/7.3 m

**Beam**  
8'6"/2.6 m

**Seating**  
10



**28**

**LOA**  
28'7"/8.7 m

**Beam**  
10'8"/3.3 m

**Seating**  
14







2105 South U.S. Highway 1  
Vero Beach, FL 32962 USA  
+1 (772)-567-9200  
info@novurania.com  
www.novurania.com

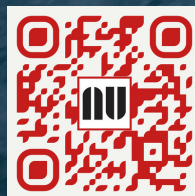

*Specifications subject to changes without notice.  
Weight and dimensions are subject to variation.*