

DL SERIES



*It is not just about building and designing
boats, it is what we love to do*

Our passion for detail and sophisticated Italian design has been our secret since the 1960s.

To meet the needs of our clients, in the 1990s our inhouse production was moved from Italy to Florida, one of the most developed marine areas in the world.

Today, Novurania continues to lead the market. Our heritage and innovation guarantee the production of exceptionally beautiful as well as high-quality boats and luxury yacht tenders.

A know-how passed on for more than half a century

Since the beginning, we controlled the main phases of the value chain to guarantee excellence and high quality.

We manufacture our own inflatable tube fabric, coated with neoprene CR on the inside and with Hypalon CSM on the outside, ensuring our vessels durability in strength as well as time.

We are revolutionizing the industry by producing the highest performance line of inflatable boats. We place equal care on the exterior appearance and on the internal technical engineering.



NOVURANIA

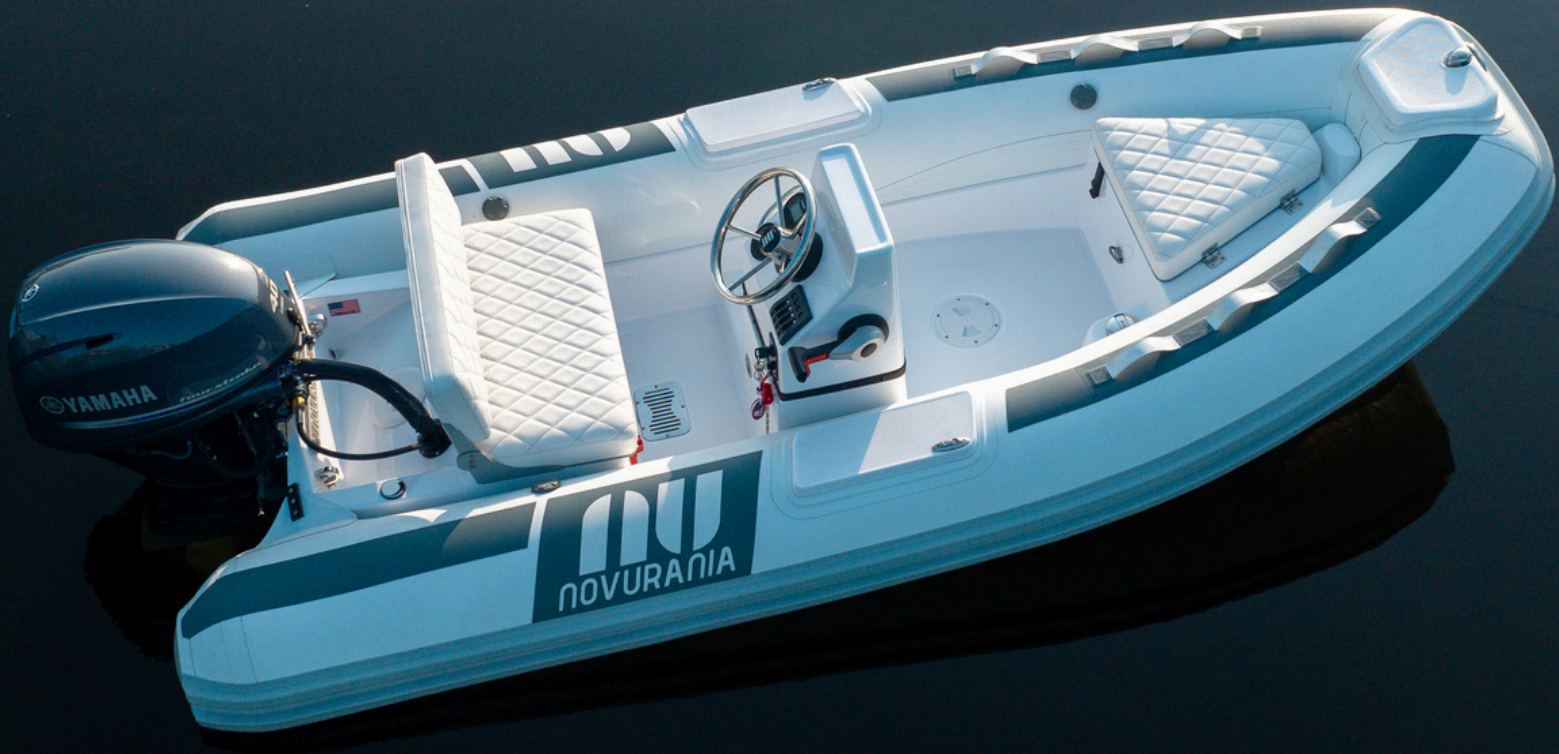

ΝΟΥΡΑΝΙΑ

YAMAHA





NOVURANIA





DL SERIES



335

360

400

430

460

550







DL 335



The smallest Novurania in the making.
The perfect fit for different yacht garages and hydraulic swim platforms.

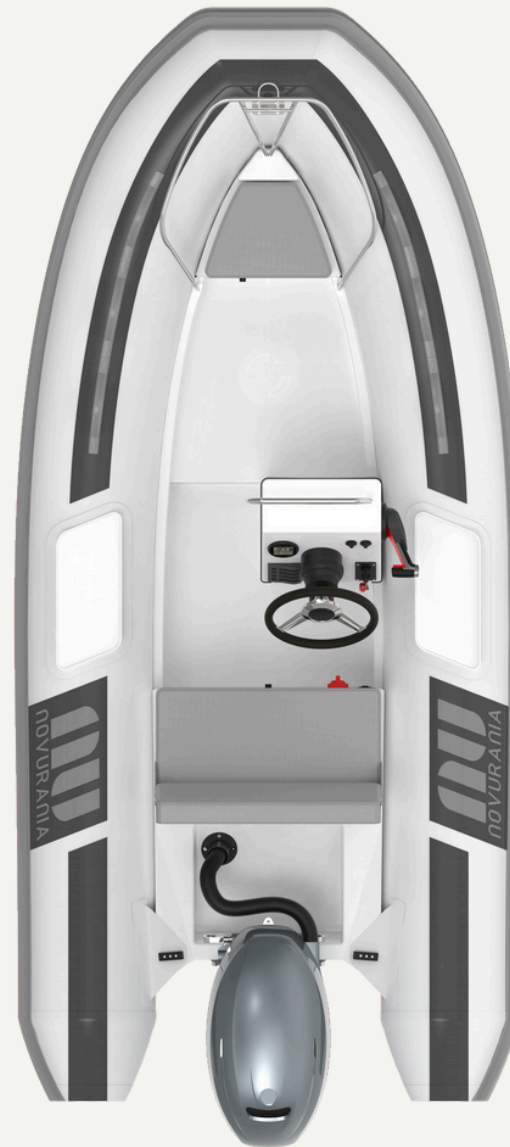
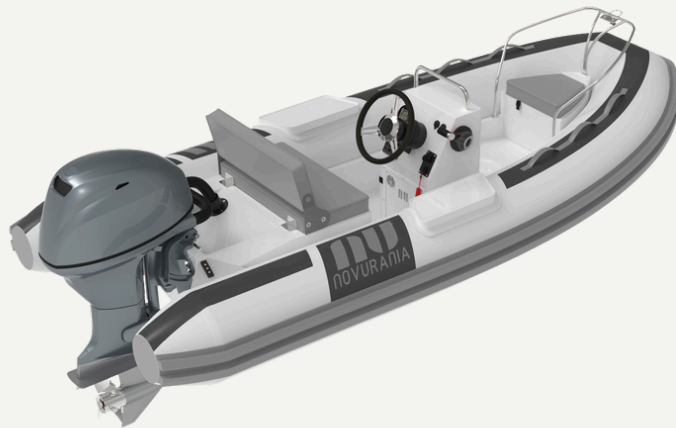

LOA 11'2"/3.4 m	Beam 5'2"/1.6 m	Seating 4
Max speed 28 mph	Fuel capacity 8 gal./30 l	Water capacity -
Max HP 30 HP OB	CE Category C	Dry weight 645 lbs/290 kg (incl. engine)



DL 360



The most requested tender among 50 footer yachts, the DL 360 can carry up to 6 people.

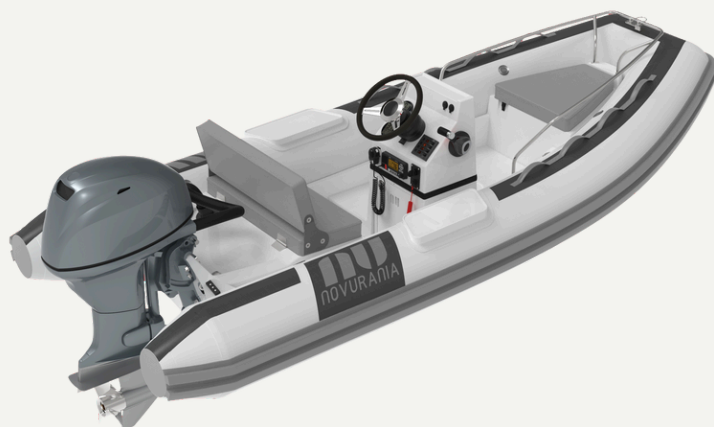

LOA 11'10"/3.6 m	Beam 5'6"/1.7 m	Seating 6
Max speed 32 mph	Fuel capacity 8 gal./30 l	Water capacity -
Max HP 40 HP OB	CE Category C	Dry weight 715 lbs/325 kg (incl. engine)



DL 400



The DL 400 is the perfect mix of comfortability and performance. This compact tender is agile and easy to maneuver.



LOA 13'5"/4.1 m	Beam 6'3"/1.9 m	Seating 6
Max speed 36 mph	Fuel capacity 10 gal./38 l	Water capacity -
Max HP 50 HP OB	CE Category C	Dry weight 860 lbs/390 kg (incl. engine)



DL 430



The DL 430 is Novurania best seller. This model has proven to be extremely versatile and well fitting a wide variety of yachts as well as uses.

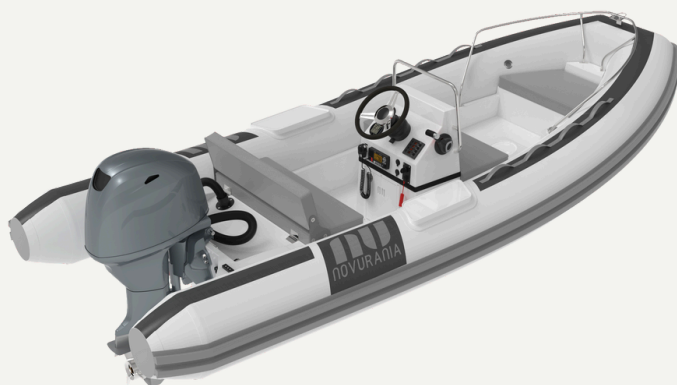

LOA 14'2"/4.3 m	Beam 6'3"/1.9 m	Seating 7
Max speed 43 mph	Fuel capacity 10 gal./38 l	Water capacity -
Max HP 70 HP OB	CE Category C	Dry weight 880 lbs/400 kg (incl. engine)



DL 460



The DL 460 is the first in its range with a wider beam of 7.6 feet. This tender satisfies the need for a greater deck and seating space.

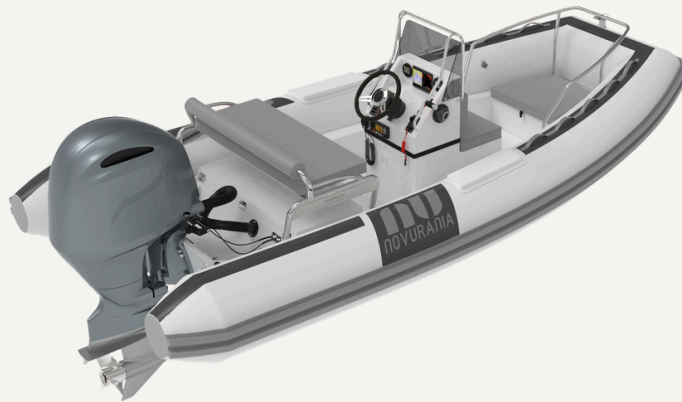

LOA 15'1"/4.6 m	Beam 7'3"/2.2 m	Seating 8
Max speed 45 mph	Fuel capacity 22 gal./83 l	Water capacity 6 gal./23l
Max HP 100 HP OB	CE Category C	Dry weight 1220 lbs/550 kg (incl. engine)



DL 550



The DL 550 is the largest of the Series. Perfect for day trips and excursions. This tender can transport up to 9 people.

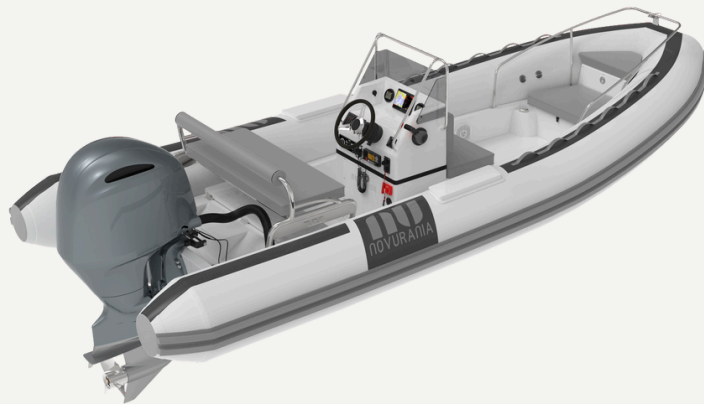

LOA 18'1"/5.5 m	Beam 7'8"/2.3 m	Seating 9
Max speed 47 mph	Fuel capacity 22 gal./83 l	Water capacity 9 gal./34l
Max HP 130 HP OB	CE Category C	Dry weight 1420 lbs/645 kg (incl. engine)





335

LOA
11'2"/3.4 m
Beam
5'2"/1.6 m
Seating
4



360

LOA
11'10"/3.6 m
Beam
5'6"/1.7 m
Seating
6



400

LOA
13'5"/4.1 m
Beam
6'3"/1.9 m
Seating
6

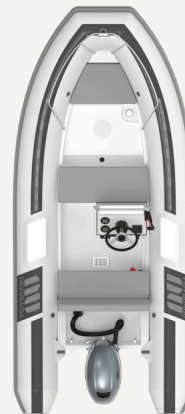

430

LOA
14'2"/4.3 m
Beam
6'3"/1.9 m
Seating
7



460

LOA
15'1"/4.6 m
Beam
7'3"/2.2 m
Seating
8



550

LOA
18'1"/5.5 m
Beam
7'8"/2.3 m
Seating
9







2105 South U.S. Highway 1
Vero Beach, FL 32962 USA
+1 (772)-567-9200
info@novurania.com
www.novurania.com

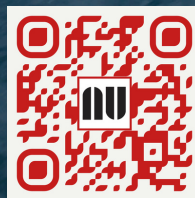

*Specifications subject to changes without notice.
Weight and dimensions are subject to variation.*